



stc

Reference Offer (RO)

Annex C

Technical Information

Version number :	Final Version
Version date :	Nov, 2022
Date of original Issue:	10 th December 2018
Authority for issue :	GM, Commercial Regulation

Document History & Version Control Record

Name of document	Technical Information
Author	Director, Regulatory WBU
Authorised Officer	GM, Commercial Regulation
Description of document	Contains all the Technical Information related to the wholesales services provided by stc .
Approved by	CITC

Version No.	Version Date	Authorised Officer	Amendment Details
1.0	December,2018	GM, Regulatory Affairs	
2.0	March, 2020	GM, Commercial Regulation	
3.0	January, 2022	GM, Commercial Regulation	
4.0	November, 2022	GM, Commercial Regulation	

Table of Contents

1	stc Fixed Core Telephone Network	5
2	stc GSM Mobile Network	6
3	Point Of Interconnection (POI)	7
4	Switching Network Interconnection	9
5	Interconnect Links and Routing	10
6	Transport Network Topology	13
7	Signalling Network	16
8	Synchronisation.....	17
9	Interface Standards.....	18
10	Numbering	19
11	Wholesale Bitstream Access Service (Fiber To The Home (FTTH))	21
12	Wholesale Bitstream Access Service (Fiber To The Business (FTTB)).....	22
13	Data Center (DC) Services.....	22
14	Ducts Service	23
15	Dark Fiber.....	24
16	IBS (In-Building Solutions).....	25

Attachments

- Attachment 1: Distribution Frame Characteristics DDF and ODF
- Attachment 2: Points of Interconnection & Signalling Point Codes (POIs & SPCs)
- Attachment 3: Saudi Arabia SS7 Signalling Standard (SA-ISUP & MTP)
- Attachment 4: NXX Number Ranges of **stc** Exchanges
- Attachment 5: **stc** Synchronisation Scheme
- Attachment 6: **stc GSM** Mobile Network

1 stc Fixed Core Telephone Network

1.1 The current stc Fixed Telephone Core Network is illustrated in Figure 1 below. The stc Fixed Network is composed of legacy PSTN, NGN and IMS Networks. There are 4 TDM IGW and 2 IP IGW (IPX). The PSTN is the original Fixed Voice Network which is comprised of Service nodes (SN) and Local Exchanges (LE). There are 26 SN sites in the network. The NGN is deployed in 5 regions (Central, Eastern, Western, Northern and Southern region). The Media Gateway (MGW) serves as the trunk gateway to interconnect the NGN with the PSTN and other Networks. The IMS is deployed in 3 regions (Riyadh, Jeddah, Dammam). The TDM Voice IGW is deployed on 4 sites (Riyadh, 2 in Jeddah, and Dammam) while IP IGW is deployed in Riyadh and Jeddah Regions only.

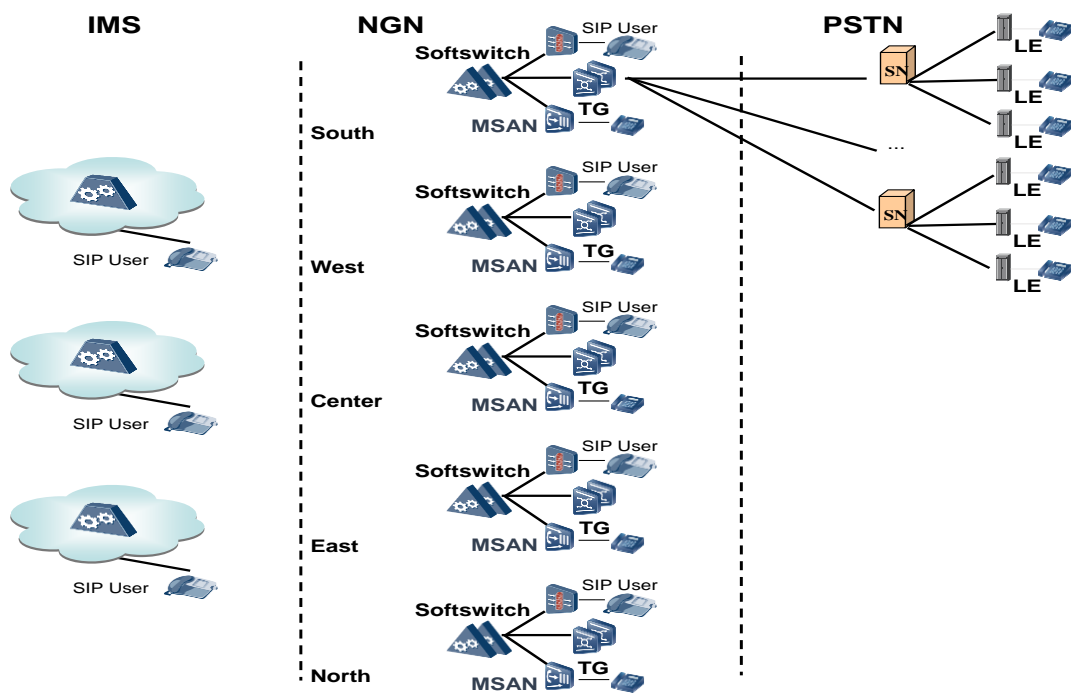

Figure 1: Overview of stc Fixed Telephone Network

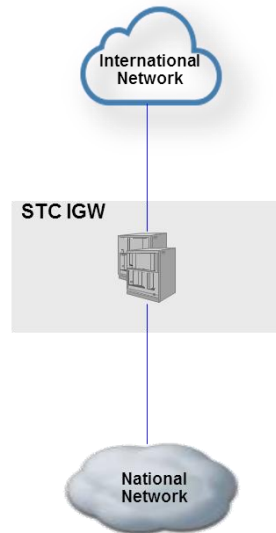

Fig. 1.1 : Overview of Voice IGW Network

1.2 The Local Exchange (LE) is the basic building block for customer access to **stc**'s PSTN. Local Exchanges provide customer connectivity via the access network. Most Local Exchanges also parent Remote Units (or Remote Switching Units), which extend the geographic area over which customers are served. Service Nodes are the major switching elements in the network and they provide national transit capability, in addition to providing customer connectivity via the access network.

2 stc GSM Mobile Network

2.1 The details of the **stc GSM Mobile Network** are contained in Attachment 6 (**stc GSM Mobile Network**) to this Annex C.

3 Point Of Interconnection (POI)

- 3.1 **stc** will physically interconnect its Network with that of the Other Licensed Operator (OLO) at designated Points of Interconnection (POIs) associated with a number of nominated Interconnect Nodes which comprise SNs, IGWs and MSC-ICGs (Mobile Switching Centre- Interconnection Gateways). The POI is defined as the point between the **stc** digital distribution frame (DDF) or optical distribution frame (ODF), connected to the nominated SN/IGW/MSC-ICG and the DDF/ODF of the Other Licensed Operator's designated Interconnection Node, as illustrated in Figure 2 below.
- 3.2 As the planned decommissioning of the **stc** Fixed Network Service Nodes continues in the future, in the case of new requests from the OLOs for Interconnection with the **stc** Fixed and Mobile Network, the OLOs will have to consider the Pol options that are available at that time based on the prevailing technology trends, whereas currently the **stc** POIs are based on Service nodes and Transit Switching Centres (TSCs).
- 3.3 The technical characteristics of the connection at the DDF/ODF will fulfil the requirements provided in Attachment 1 (Characteristics of DDF and ODF).
- 3.4 There are three modes of Interconnection, namely: Customer Sited Interconnection (CSI) as shown in Figure 2, In Span Interconnection as shown in Figure 3 and Collocated Interconnection as shown in Figure 3.1.
- 3.5 In the CSI mode, the **stc** DDF and transmission terminal equipment will be installed at the boundary of or within the OLO site, to where **stc** technicians should be granted access. Both Parties shall come to an agreement on adequate access arrangements that will allow **stc** to fulfill its respective obligations. Should it not be possible to arrive at an agreement, such obligation will be suspended until such time as the access arrangements are agreed.

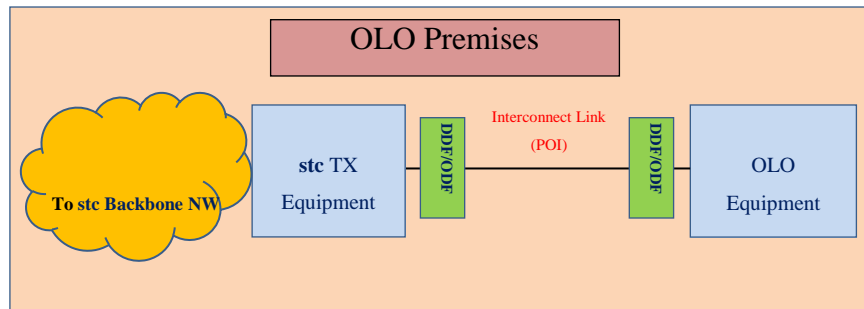

Figure 2: Customer Sited Interconnection

- 3.6 In the In Span Interconnection, the footway box is located within the curtilage of the OLO site to which both the parties run the fibre optical cable from their respective switch buildings. The Point Of Interconnection (POI) will be that point of the footway box where the duct from the Other Licensed Operator’s premises containing the relevant fibre optical cable is jointed to the footway box wall.
- 3.7 In case stc is going to establish, relocate or remove a POI (Annex C Attachment 2 POIs), stc will provide the other Service Providers with advance notice of at least 60 days of any expected changes and to seek to minimize any adverse effect of any expected changes on Interconnection service provided.

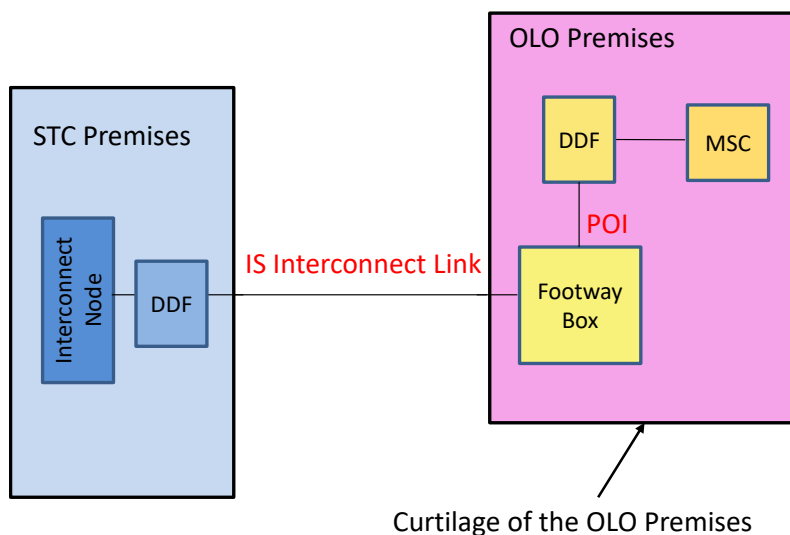

Figure 3 : In Span Interconnection

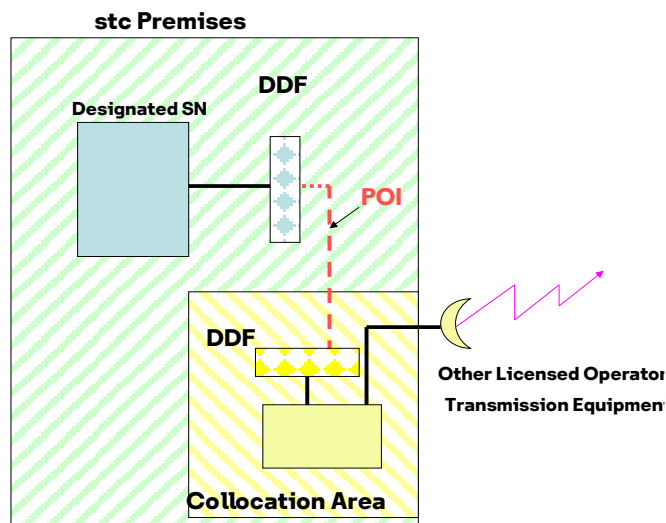

figure 3.1: Collocated Interconnection

4 Switching Network Interconnection

- 4.1 The list of SNs/POIs, as at the date of this document, is presented in Attachment 2 (Points of Interconnection & Signalling Point Codes). The list of MSC-ICGs/POIs, as at the date of this document, is presented in Attachment 6 (**stc GSM Mobile Network**). This list will be updated periodically. Additional POIs will be determined by agreement between **stc** and the Other Licensed Operator as part of the Network Plan and will be consistent with Clause 4.2 below.
- 4.2 To establish and maintain Interconnection between the stc Network and the Other Licensed Operator's Network it is necessary for the Other Licensed Operator to:
- a) Establish interconnection with **stc** at Points of Interconnection offered by **stc** at Interconnect Nodes which include, IGW, MSC-ICG or at any other point of Interconnection which is technically and economically feasible.
 - b) For Interconnection with a Kingdom wide OLO Public Network, the initial requirement is for Interconnection at a minimum of two (2) Points of

Interconnection. (The details of the initial interconnection arrangement will be agreed during the initial network planning process.)

5 Interconnect Links and Routing

- 5.1 Interconnect Links will be used as necessary to provide interconnection routes for the conveyance of the Other Licensed Operator's traffic into the **stc** network. Routes will be established in accordance with the Other Licensed Operator's agreed Network Plan and capacity forecasts as stipulated in Annex E (Forecasting).
- 5.2 Until routes are mature and traffic volumes become stable, interconnect routes will be uni-directional. At a later stage, bi-directional operation of these routes will be considered.
- 5.3 Route segregation will be based on traffic type (e.g. calls to geographic-national number ranges, mobile number ranges, international, etc.) and economic considerations. This will be agreed between the Parties.
- 5.4 The Other Licensed Operator will be responsible for those routes on which it sends traffic to **stc** and will dimension the routes to meet the target Unsuccessful Call Termination Ratio stated in Annex I (Quality of Service Measures).
- 5.5 Interconnected voice calls to geographic number ranges will employ far end hand-over principles. This means that calls to geographic number ranges will only be permitted through the interconnect Node POI's that are nearest to those ranges. Depending on the selected set of interconnect Node POI's, a table will be established as part of the Network Plan described in Annex H (Operations and Maintenance Manual) that will associate each number range (NXX) with the permitted POIs.
- 5.6 The main traffic routing categories, corresponding to the basic services, are illustrated in the Figure 4 below as follows:

- Voice calls terminating on **stc** geographic number ranges. Such calls will be routed within the OLO Network and handed over to **stc** at the Interconnect Node POI nearest to the called destination number ranges.
- Voice calls terminating on **stc** mobile number ranges. Such calls will be routed from the OLO's network to the nearby **stc** MSC-ICG POI as listed in Annex C Attachment 6.
- OLO's voice calls offered for international conveyance – The Interconnection to the International Gateway directly or indirectly via an Interconnect.

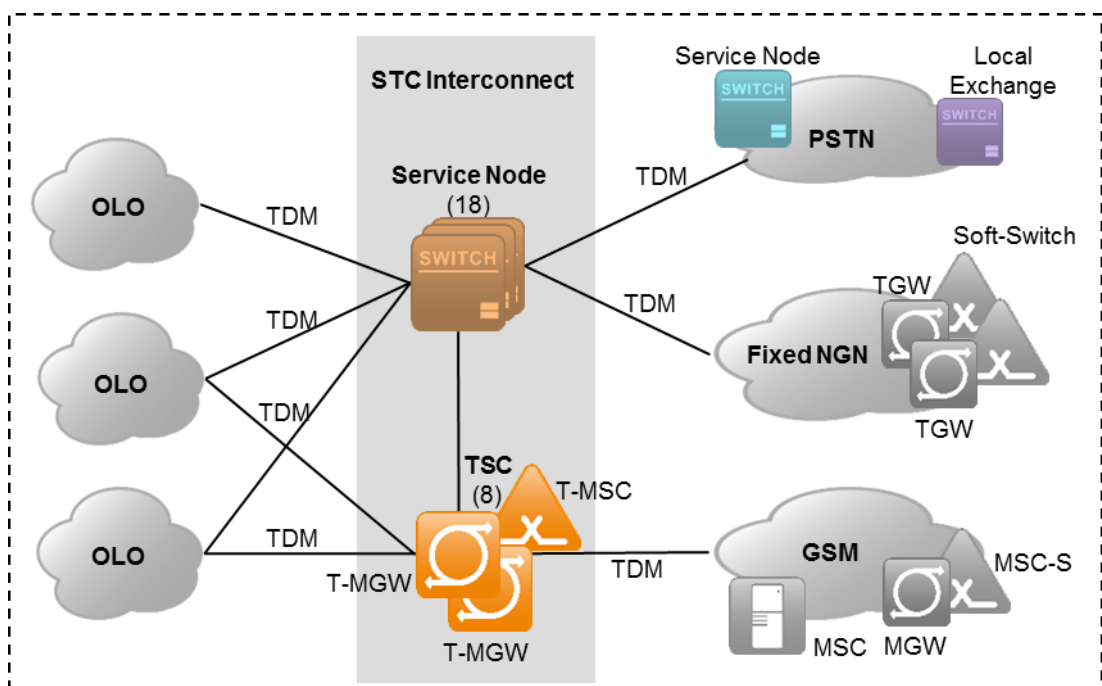

Figure 4a: Interconnection between stc and OLOs

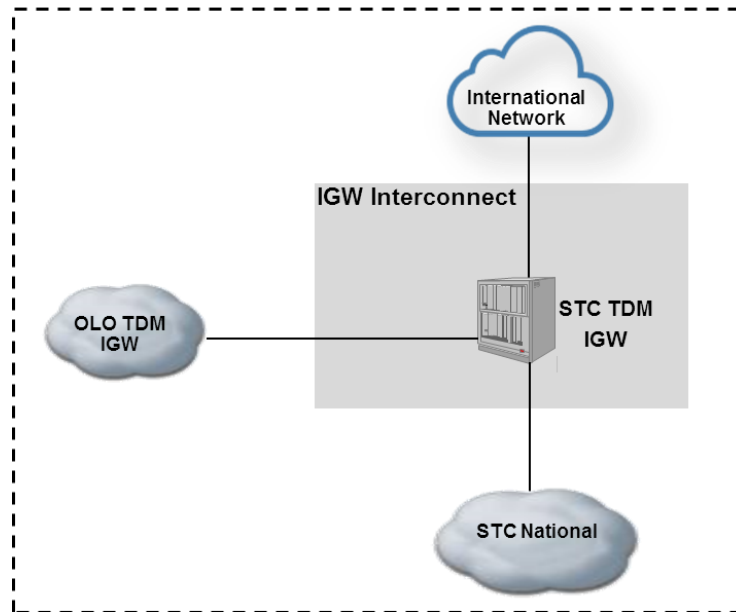

Figure4b: Interconnection between stc IGW and OLO

- 5.7 The Other Licensed Operator shall be responsible for the number translation of short code dialled digits. These calls will be presented to the **stc** Network using the appropriate translated geographic destination number based on the specific location of the calling party on a call-by-call basis. **stc** will provide the appropriate lookup tables within the agreed Network Plan as per Annex H (Operations and Maintenance Manual).
- 5.8 **stc** provides the Short Messaging Service (SMS) Termination Service to the Other Licensed Operator. This service involves the sending of messages to the mobile phones or other devices belonging to the customers of **stc** and originated from the mobile phones or other devices belonging to the customers of the Other Licensed Operator. The SMS Termination Service is carried over the signaling links provisioned by the OLO and **stc** based on the mutually agreed forecasts. The Short Messaging Service is a messaging service which uses the CCITT No.7 MAP protocol and generally conforms to the GSM technical specifications of the GSM 03.40, GSM 04.11 and GSM 09.02 (as amended from time to time).

-
- 5.9 **stc** provides the Multimedia Messaging Service (MMS) Termination Service to the Other Licensed Operator. This service involves the sending of data messages to the mobile phones or other devices belonging to the customers of **stc** and originated from the mobile phones or other devices belonging to the customers of the Other Licensed Operator. The MMS Termination Service is carried over the Interconnect Links provisioned by the OLO and **stc** based on the mutually agreed forecasts. The Multimedia Messaging Service is a messaging service which uses the 3GPP and OMA protocols which comply with the MM1, MM2, MM3, MM4, MM5, MM6, MM7, MM8 and MM9 specifications (as amended from time to time).

6 Transport Network Topology

- 6.1 The **stc** core network is primarily optical fibre rings, operating at the STM-64, STM-16 STM-4 and STM-1 rate (10 / 2.5 / 0.622 / 0.155 Gb/s). Some heavily utilised routes are equipped with dense wavelength division multiplexing (DWDM). The SDH transport network is part of the core PSTN network, but it also serves all the other **stc** networks, namely: Data and Mobile.
- 6.2 The rings are configured as self-healing rings and provide connectivity between **stc** SNs, MSCs, and IGWs. There are also additional rings in the major cities and further access fibre rings connecting some major buildings and customers. This topology is illustrated in Figure 5.
- 6.3 This **stc** transmission infrastructure will also be utilized for the provision of Wholesale Leased Line Services and Interconnect Link Services.

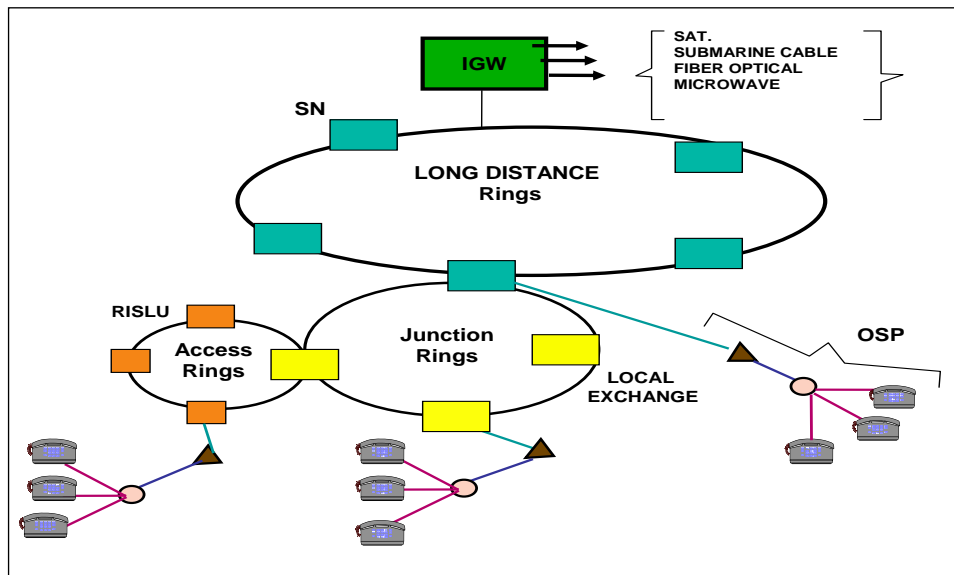

Figure 5: General Architecture of the Transport of the Fixed Telephone Network

6.4 The **stc** core network is primarily optical fibre DWDM and there are two types of DWDM systems, service System (SS) (Refer to the sample in Figure 6) and high speed/Metro DWDM (Refer to the sample in Figure 7).



Figure 6: DWDM Service System sample

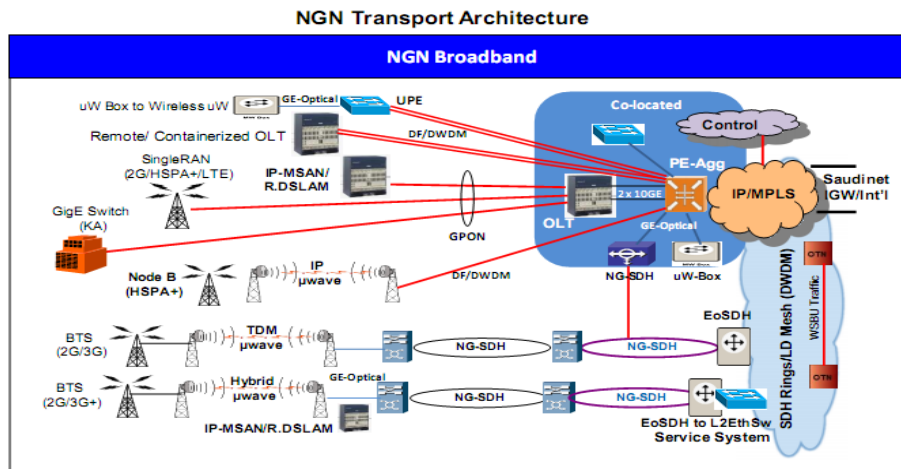

Figure 9: General Architecture of traffic aggregation backhauling to core network

7 Signalling Network

- 7.1 The **stc** Network utilises Signalling System No.7 (SS7) in accordance with ITU-T 7xx series standards with options as adapted to the Kingdom of Saudi Arabia, as described in Attachment 3 (Saudi Arabia SS7 Signalling Standard) of this Annex C, which provides the standard specifications for Layers 1, 2 and 3 of the Message Transfer Part (MTP). This Attachment 3 also provides the standard specifications for the ISDN User Part (SA-ISUP). The signalling point codes (SPCs) for the Service Node POIs are provided in Attachment 2 (Points of Interconnection & Signalling Point Codes) of this Annex C and the SPCs for the MSC-ICG POIs are provided in Attachment 6 (**stc GSM Mobile Network**).
- 7.2 The utilisation of SS7 links shall be maintained within the guidelines of ITU-T Q.706 Recommendations of 0.2 erlang under normal load and 0.4 erlang under high load (e.g. change over of a parallel link). Higher loads may be permitted as appropriate in the future (e.g. 0.3/0.6 normal/high).
- 7.3 As a part of the Network Plan, referred to in Annex H (Operations and Maintenance Manual), a set of SS7 signalling tests will be performed in order to insure the compatibility and interoperability between **stc** and the Other Licensed Operator Networks at the 3 MTP levels as well as ISUP & Supplementary Services levels. These tests are extracted from the ITU-T Q.780, Q.781, Q.782, Q.784 and Q.785 Recommendations.

7.4 Figure 10 below shows an architectural schematic diagram of the **stc** Signalling Network, which supports the **stc** Network. In addition, the necessary connections of the Other Licensed Operator signalling transfer points (OLO STPs) and International Gateways (IGWs) to the **stc** national STPs (NSTPs) are shown. The SPCs for the NSTP's are (1000, 1001, 2000, 2001).

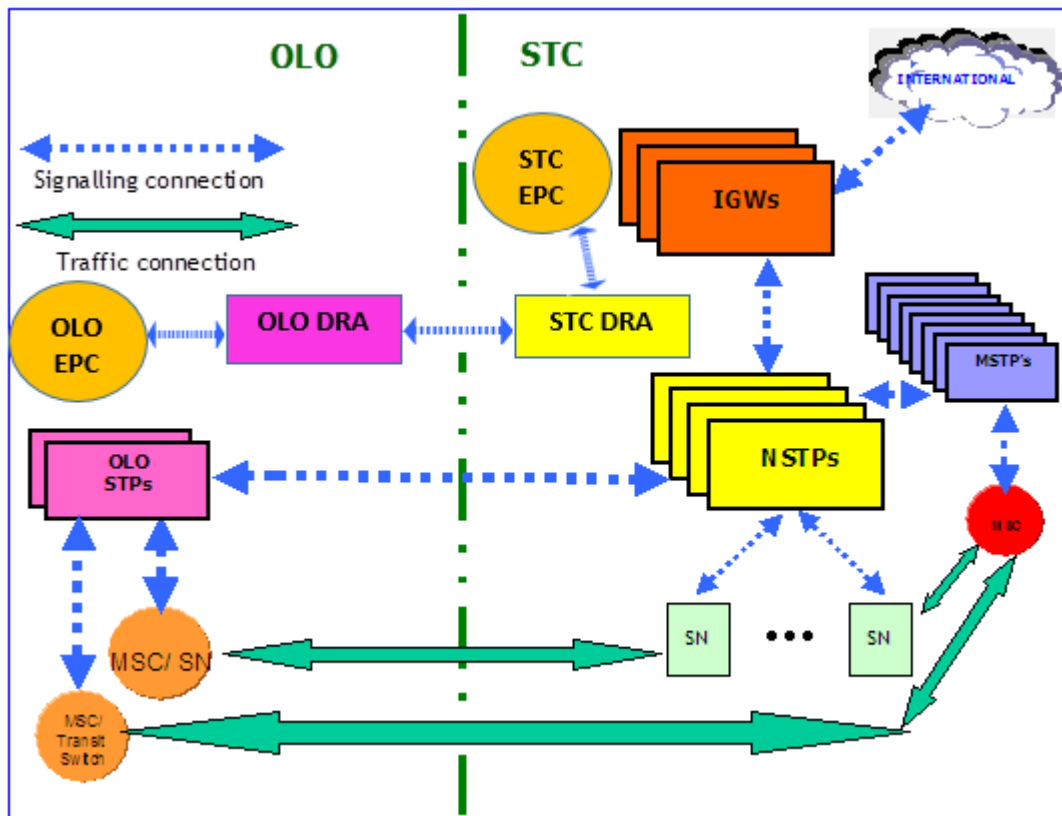

Figure 10 : Signalling Interconnection

8 Synchronisation

8.1 The **stc** Network Synchronisation is in line with relevant ITU-T recommendations. In order to establish Interconnection, the Other Licensed Operator will fulfil the timing performance requirements of ITU-T recommendation G.811. This can be achieved for Plesiochronous Mode by deriving reference timing from OLO's own Stratum-1 clock or the OLO will receive the master timing signal from **stc**.

- 8.2 The specification of the timing system that is required in order to ensure proper operation of the interconnected Networks is given in Attachment 5 (**stc** Synchronisation Scheme).
- 8.3 Licensed operators are responsible for the management of Synchronisation on their respective networks.

9 Interface Standards

9.1 Optical STM-1 Interfaces

9.1.1 The optical STM-1 interface will be as specified by ITU-T G.957

(i) 155 Mbit/s STM-1 Interface (Application Class S-1.1 for Short Hauls)

- Bit rate 155,520 kbit/s \pm 20 ppm
- Code binary (NRZ)
- Wavelength range 1261 nm to 1360 nm
- Attenuation 10 dB to 28 dB

(ii) 155 Mbit/s STM-1 Interface (Application Class L-1.1 for Long Hauls)

- Bit rate 155,520 kbit/s \pm 20 ppm
- Code binary (NRZ)
- Wavelength range 1285 nm to 1330 nm
- Attenuation 10 dB to 28 dB

(iii) 155 Mbit/s STM-1 Interface (Application Class L-1.2 for Long Hauls)

- Bit rate 155,520 kbit/s \pm 20 ppm
- Code binary (NRZ)
- Wavelength range 1480 nm to 1580 nm
- Attenuation 10 dB to 28 dB

9.1.2 Optical STM-4 interface will be specified by ITU-T G.957

- (i) 662 Mbit/s STM-4 interface (Application Class S-4.1 for short haul)

-
- Bit rate 622,080 Kbit/s
 - Code Binary
 - Wavelength rage 1293 - 1334 / 1274 – 1356 nm
 - Attenuation 0 – 12 dB
- (ii) 622 Mbit/s STM-4 interface (Application Class L.4.1 for long haul)
- Bit rate 622,080 Kbit/s
 - Code Binary
 - Wavelength range 1300 - 1325 / 1296 – 1330 nm
 - Attenuation 10 - 24 dB
- (iii) 622 Mbit/s STM-4 interface (Application Class L.4.2 for long haul)
- Bit rate 622,080 Kbit/s
 - Code Binary
 - Wavelength range 1480 – 1580 nm
 - Attenuation 10 – 24 dB

10 Numbering

10.1 Number Ranges

10.1.1 **stc** and the Other Licensed Operator will ensure that sufficient and correct Numbering information is sent from one Network to the other for correct delivery of Calls. The Parties will convey to each other telephone numbers in the national and international formats as contained in the National Numbering Plan issued by CITC. In particular for mobile number portability, the routing number (RN) used for the routing of the voice traffic as well as the SMS and MMS traffic to **stc** mobile Network is 1545.

10.1.2 **stc** exchanges in the fixed network are designated by their site number, together with the associated NXX number ranges. Attachment 4 provides a list with NXX's associated with all exchanges in the **stc** Network.

10.2 Calling Line Identification Presentation (CLIP).

10.2.1 **stc** and the Other Licensed Operator will pass the CLI for all Calls for which Call origination and Call termination services are provided, including the traffic which is forwarded from another Network.

10.2.2 For calls handed over from an authorized overseas system, **stc** will convey, to the extent received, the calling subscriber number associated with those calls.

10.2.3 The Parties will resolve any service issues arising from the provision of CLIP from the other Party's network, where the CLI is not an actual directory number. A list of all such non-subscriber CLIs ("Dummy CLIs") will be notified by each Party to the other Party in writing for those Dummy CLIs already in use. The list will be updated from time to time to include those planned for use and those no longer in use. Twenty-eight (28) Calendar Days' advance notice of the commencement date will be given for Dummy CLIs planned for use.

10.2.4 For calls for which CLIP is not available, such as calls from customer service operator positions, the category of the calling customer will be clearly indicated in the signalling message.

10.2.5 The Parties will comply with the following requirements and safeguards:

- Each Party will not manipulate the CLI of the original calling customer and the original calling customer CLI will accordingly be passed on in the conveyance of a Call;
- Each Party will not, in the handling of outgoing traffic, manipulate the access code dialled by the calling customer;

- Each Party will set the A-bit of the Forward Call Indicator (FCI) of the Initial Address Message (IAM) of ISDN User Part (ISUP) to the value "1" to identify an international incoming call.

11 Wholesale Bitstream Access Service (Fiber To The Home (FTTH))

11.1 General

- 11.1.1 stc will supply the FTTH to the Other Licensed Operator
- 11.1.2 For the avoidance of doubt, the process must be initiated by the Other Licensed Operator if it wishes to acquire the FTTH Service
- 11.1.3 Notwithstanding the Interconnection of the stc Network and the Other Licensed Operator's network, stc shall have no obligation to provide the FTTH Service at sites not designated as Points of Interconnection (POI).
- 11.1.4 stc will only be required to provide the FTTH Service to the Other Licensed Operator to the extent that the Other Licensed Operator has complied with Annex H (Operations and Maintenance Manual)

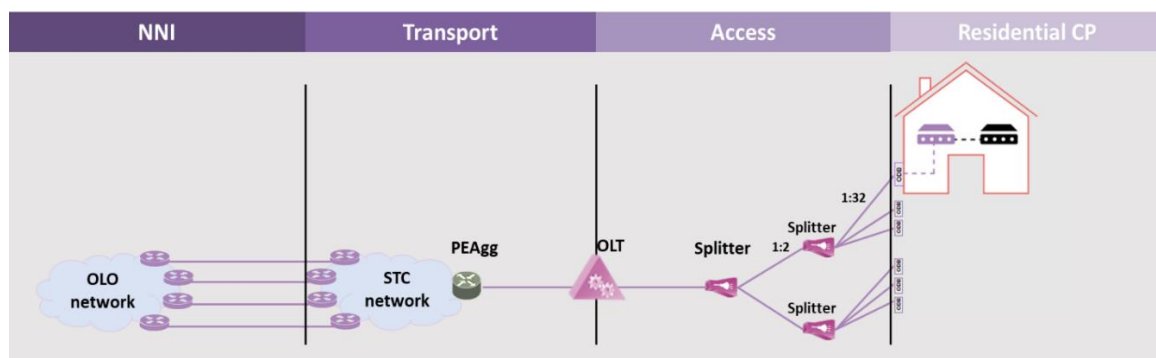

Figure 11: FTTH Service

12 Wholesale Bitstream Access Service (Fiber To The Business (FTTB))

12.1 General

- 12.1.1 stc will supply the FTTB to the Other Licensed Operator
- 12.1.2 For the avoidance of doubt, the process must be initiated by the Other Licensed Operator if it wishes to acquire the FTTB Service
- 12.1.3 Notwithstanding the Interconnection of the stc Network and the Other Licensed Operator's network, stc shall have no obligation to provide the FTTB Service at sites not designated as Points of Interconnection (POI).
- 12.1.4 stc will only be required to provide the FTTB Service to the Other Licensed Operator to the extent that the Other Licensed Operator has complied with Annex H (Operations and Maintenance Manual).

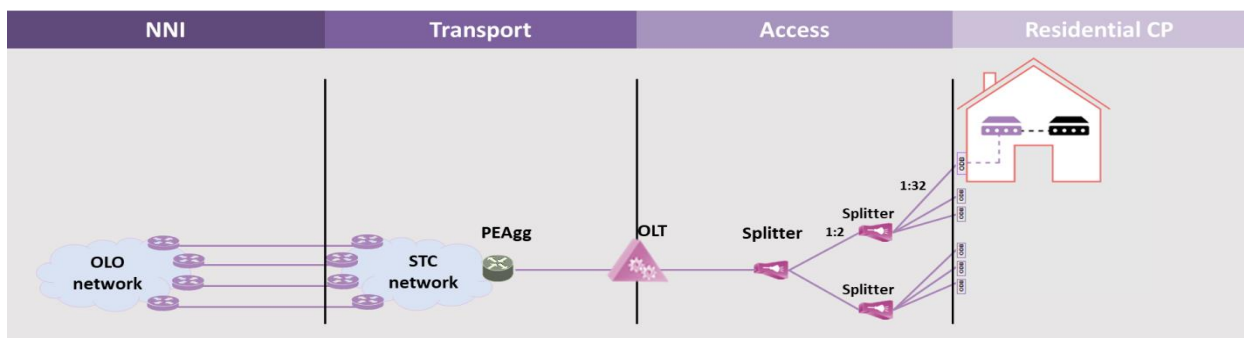

Figure 12: FTTB Service

13 Data Center (DC) Services

13.1 General

- 13.1.1 stc will supply the Data Center (DC) Collocation to the Other Licensed Operator
- 13.1.2 For the avoidance of doubt, the process must be initiated by the Other Licensed Operator if it wishes to acquire the Data Center (DC) Collocation Service

- 13.1.3 Notwithstanding the Interconnection of the stc Network and the Other Licensed Operator's network, stc shall have no obligation to provide the Data Center (DC) Collocation Service at sites not designated as Points of Interconnection (POI).
- 13.1.4 stc will only be required to provide the Data Center (DC) Collocation Service to the Other Licensed Operator to the extent that the Other Licensed Operator has complied with Annex H (Operations and Maintenance Manual).
- 13.1.5 This DC Collocation Service offers proper power, cooling, and security to host businesses' computing hardware and servers. The DC Collocation components include – rack + 3.7kw is standard (extra power is additional) DC environmental/monitoring, current AC/DC options, Air-Cond, overhead fiber drop, are included.
- 13.1.6 The DC Collocation Service provides a high-performance environment for the (Customer/Recipient) critical IT infrastructure. the (Customer/Recipient) can benefit from a 100% uptime SLA and focus on core business rather than managing a data centre. Additionally, the DC Collocation provides dedicated, private connection options to hundreds of networks, cloud and IT service providers to help streamline your architecture.
- 13.1.7 The DC Collocation Service space options range from single cabinets to multi-rack cages to private suites, offering customers the flexibility to expand within a stable and secure environment without the inconvenience of relocating their infrastructure.

14 Ducts Service

14.1 General

- 14.1.1 stc will supply the Ducts Service to the Other Licensed Operator
- 14.1.2 For the avoidance of doubt, the process must be initiated by the Other Licensed Operator if it wishes to acquire the Ducts Service

- 14.1.3 stc will only be required to provide the Ducts Service to the Other Licensed Operator to the extent that the Other Licensed Operator has complied with Annex H (Operations and Maintenance Manual).

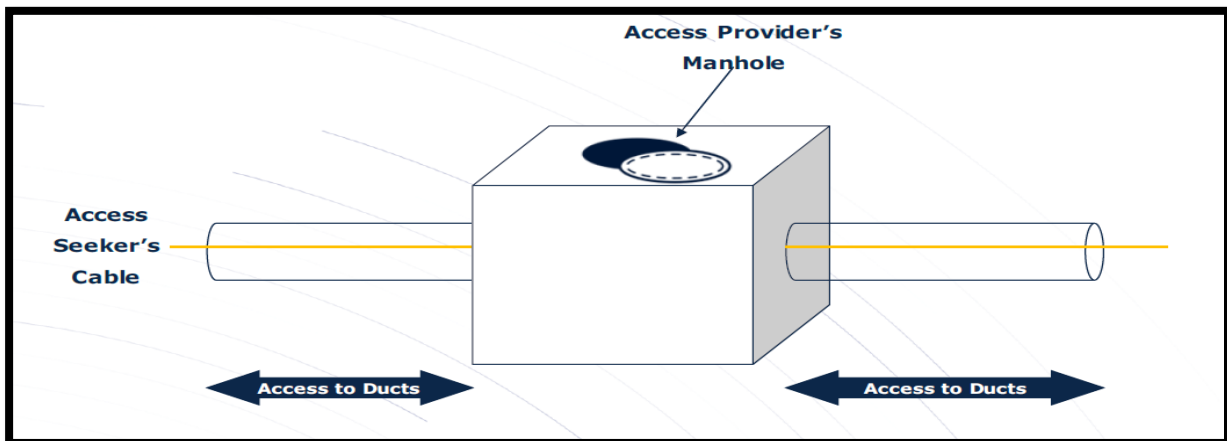

Figure 14: Ducts

15 Dark Fiber

15.1 General

- 15.1.1 stc will supply the Dark Fiber Service to the Other Licensed Operator.
- 15.1.2 For the avoidance of doubt, the process must be initiated by the Other Licensed Operator if it wishes to acquire the Dark Fiber Service
- 15.1.3 stc will only be required to provide the Dark Fiber Service to the Other Licensed Operator to the extent that the Other Licensed Operator has complied with Annex H (Operations and Maintenance Manual)
- 15.1.4 STC owns and operates fiber optic communications system ("STC Fiber Network"), is licensed to grant Indefeasible Rights of Use (IRU) and other services to its capacity

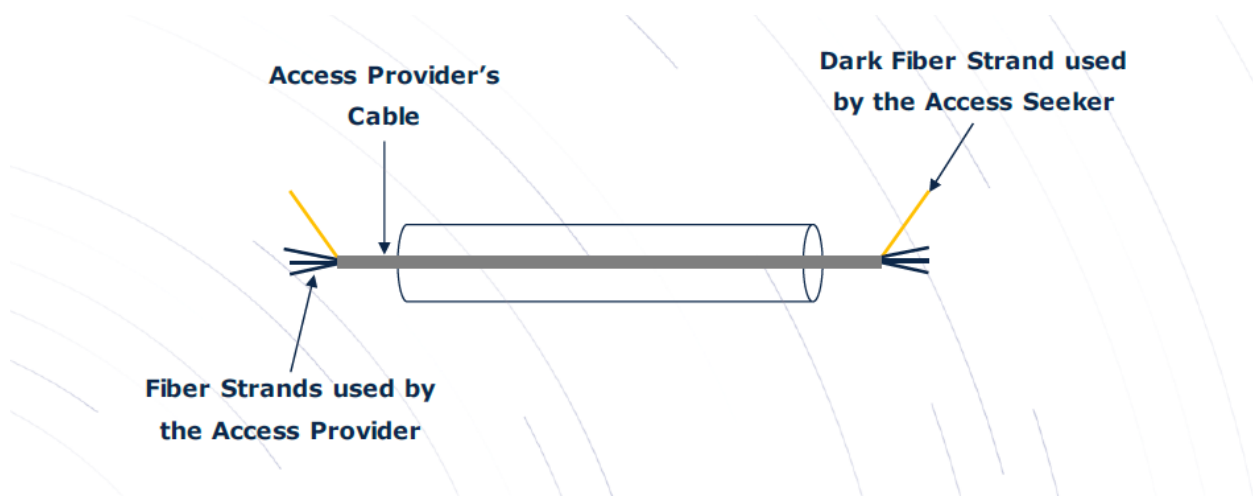

Figure 15: Dark Fiber

16 IBS (In-Building Solutions)

16.1 General

- 16.1.1 It is becoming a common practice for real-estate owners to get into an exclusive partnership with a single telecom service provider "Principal Operator" for the sake of simplicity and in dealing with a single point of contact for providing IBS system, and becoming responsible for implementation and management of the Distributed Antenna System (DAS) solution in a defined building or complex (the "Site").
- 16.1.2 Whereas, the Parties consider applying a regime whereby any partnership signed by the PO to provide IBS solution in a site, the implemented systems would be available for mutual sharing by the AO "Associate Operator".
- 16.1.3 Whereas, the IBS system mutual sharing regime is intended to assist in promoting more environmentally friendly practices through the minimization of the need to construct and maintain separate systems, encouraging socially efficient investment in telecom facilities; reducing operating costs for the Parties; and ultimately providing benefits to consumers in terms of price, quality and availability of services.
- 16.1.4 The commercial terms that shall govern the Parties wishing to mutually share the IBS system implemented and managed by the PO are:

The IBS system facilities shall be mutually shared between the parties.

Operations, Administration and Maintenance of the IBS system (excluding AO's systems) shall be provided by the PO.

The AO shall procure the IBS Sharing Service from the PO on site by site basis.

16.1.5 Technical Framework

Design will be basically as SISO DAS (Single Input, Single Output). MIMO DAS (Multiple Input, Multiple Output) shall be mutually agreed between the Parties in site by site cases and shall be indicated clearly in the Survey Report (SR). The PO shall highlight the areas which will be covered using MIMO in the SR.

16.1.6 Coverage & Quality KPIS

The Design for new sites should cover the minimum Coverage & Quality KPIs, unless changes are mutually agreed by the Parties.

16.1.7 Design Submission

In order to get the full details and archive of the handed over design, the PO shall submit a full design package which includes the below items:

Mandatory Items

Expected number of users.

Link budget Calculations (EiRP table)

Antennas floor plan layouts

Coverage prediction/CWT Result

Coverage commitment

Equipment room Floor plan layout (in details including MU&RU).

Schematic diagram

Primary Operator WT.

Band and configuration for all the operators

16.1.8 Optional Items

Equipment specification

MW antenna location IF cable route (MW antenna to the ER).

16.1.9 Telecom Rooms

The parties shall agree on the average area and dimensions of STRs needed to install equipment of the AO, as well as the minimum space required to mount the AO connection facilities in the Main Telecom Room (MTR) admitting the PO equipment.

16.1.10 Considered IBS Models

The IBS models are classified based on the employed Distributed Antenna System (DAS). The DAS could be one of the following general types:

- Passive: Typically composed of standard and radiating coaxial cables, couplers and power splitters which are employed to branch the base station power to indoor Panel, Omni and/or Cable antennas in remote locations.
- Active: Typically composed of point-to-point optical fiber cables connecting one or more local fiber-optic interfaces located in the base station to one or more AC or DC power operated active heads in remote locations. The remote active heads in turn are each connected to one or more antennas, possibly via an additional amplifier.
- Hybrid: In some cases the DAS can be hybrid, i.e. having both passive and active DAS segments.